



2-PC. SCREWED END BALL VALVE 2006SW

★ **ECONOMIC PATTERN**



FEATURES

- Full port, 1/4"~3" (DN8~DN80)
- W.P. : 1000 WOG (PN63)
- W.T. : -20°C~200°C (-4°F~392°F)
- Investment casting
- Blow-out proof stem
- Locking device
- Seal welded ends
- TA-Luft approved
- Length conform to DIN 3202/4-M3-2006SWM3 (option)
- Thread type : ASME B1.20.1 (NPT)
DIN2999 & BS21
ISO228/1 & ISO7/1

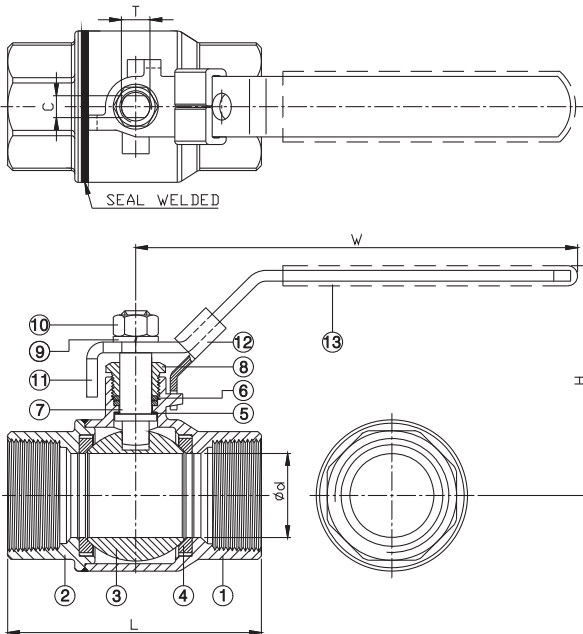

ITEM	PARTS	MATERIAL
1	BODY	ASTM A351-CF8M
2	CAP	
3	BALL	
4	SEAT	PTFE / RTFE
5	THRUST WASHER	PTFE
6	PACKING	
7	STEM	ASTM A276-316
8	GLAND NUT	AISI 304
9	SPRING WASHER	
10	STEM NUT	
11	HANDLE	
12	LOCKING DEVICE	PVC
13	HANDLE SLEEVE	

DN	d	L	H	W	C	T	Weight(kg)	Torque (N-M)	
								Action	Breakaway
8	11.5	50	48	102	5	5/16"-18UNC	0.16	2.9	3.7
10	12.5	50	48	102	5	5/16"-18UNC	0.18	3.1	4.2
15	15	58	51	102	5	5/16"-18UNC	0.22	3.5	4.5
20	20	66	57	129	6.5	3/8"-16UNC	0.34	6	9
25	25	75.5	63	129	6.5	3/8"-16UNC	0.5	6	12
32	32	88.5	74	153	8	7/16"-14UNC	0.9	7.5	18.5
40	38	98.5	81	153	8	7/16"-14UNC	1.07	16.5	27
50	50	120	94	190	9	1/2"-12UNC	1.82	23	35
65	63	146.5	130	247	12	3/4"-10UNC	3.53	32	42
80	76	165	137	247	12	3/4"-10UNC	4.96	40	50

unit:mm

NPS	d	L	H	W	C	T	Weight(lb)	Torque (in-lb)	
								Action	Breakaway
1/4"	0.45	1.97	1.89	4.02	0.2	5/16"-18UNC	0.35	25.67	32.75
3/8"	0.49	1.97	1.89	4.02	0.2	5/16"-18UNC	0.4	27.44	37.17
1/2"	0.59	2.28	2.01	4.02	0.2	5/16"-18UNC	0.49	30.98	39.83
3/4"	0.79	2.6	2.24	5.08	0.26	3/8"-16UNC	0.75	53.10	79.66
1"	0.98	2.97	2.48	5.08	0.26	3/8"-16UNC	1.1	53.10	106.21
1-1/4"	1.26	3.48	2.91	6.02	0.31	7/16"-14UNC	1.98	66.38	163.74
1-1/2"	1.5	3.88	3.19	6.02	0.31	7/16"-14UNC	2.36	146.04	238.97
2"	1.97	4.72	3.7	7.48	0.35	1/2"-12UNC	4.01	203.57	309.77
2-1/2"	2.48	5.77	5.12	9.72	0.47	3/4"-10UNC	7.78	283.22	371.73
3"	2.99	6.5	5.39	9.72	0.47	3/4"-10UNC	10.93	354.03	442.54

unit:in



8F., No.201, Sec. 2, Tiding Blvd., Neihs District, Taipei City 114, Taiwan R.O.C.
TEL: +886-2-26585800 FAX: +886-2-26582266 / 27997766

[Http://www.haitima.com.tw](http://www.haitima.com.tw)
Email: haitima@seed.net.tw