

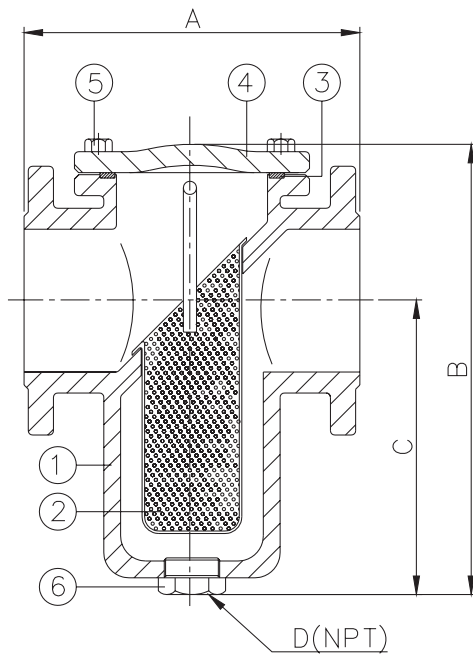

FEATURES

- 1"~12" (DN25~DN300)
- W.P. : PN16/40
CLASS 150/300
- W.T. : -20°C~200°C (-4°F~392°F)
- Investment casting



ITEM	PARTS	MATERIAL		
1	BODY	ASTM A351-CF8M	ASTM A216-WCB	ASTM A351-CF8
2	SCREEN	AISI 304		
3	SEAL	PTFE		
4	CAP	ASTM A351-CF8M	ASTM A216-WCB	ASTM A351-CF8
5	BOLT	ASTM A193-B8	ASTM A193-B7	ASTM A193-B8
6	BLOW OFF PLUG	ASTM A351-CF8	ASTM A216-WCB	ASTM A351-CF8

SIZE	D
1"	1/2"
1-1/2"	1/2"
2"	1"
2-1/2"	1"
3"	1"
4"	1"
5"	1"
6"	1"
8"	1"
10"	2"
12"	2"

DN	CLASS 150			CLASS 300			PN 16			PN 40		
	A	B	C	A	B	C	A	B	C	A	B	C
25	152	174	77	163.6	174	77	152	174	77	163.6	174	77
40	164	216	120	177.2	222	120	173	216	120	177.2	222	120
50	210	216	120	224	216	120	210	216	120	224	216	120
65	222	260	160	227	249.2	136.5	222	260	160	227	249.2	136.5
80	254	306	200	272	292	171.5	254	306	200	272	292	171.5
100	290	390	254	307	380	244	290	390	254	307	380	244
125	336	430	280	363	410	280	336	430	280	363	410	280
150	380	410	270	396	398	270	400	410	270	396	398	270
200	476	560	340	507	490	320	500	560	340	507	490	320
250	508	685	340	542	542	365	508	685	340	542	542	365
300	666	760	420	670	760	420	666	760	420	670	760	420

unit:mm

NPS	CLASS 150			CLASS 300			PN 16			PN 40		
	A	B	C	A	B	C	A	B	C	A	B	C
1"	5.98	6.85	3.03	6.44	6.85	3.03	5.98	6.85	3.03	6.44	6.85	3.03
1-1/2"	6.46	8.5	4.72	6.98	8.74	4.72	6.81	8.5	4.72	6.98	8.74	4.72
2"	8.27	8.5	4.72	8.82	8.5	4.72	8.27	8.5	4.72	8.82	8.5	4.72
2-1/2"	8.74	10.24	6.3	8.94	9.81	5.37	8.74	10.24	6.3	8.94	9.81	5.37
3"	10	12.05	7.87	10.71	11.5	6.75	10	12.05	7.87	10.71	11.5	6.75
4"	11.42	15.35	10	12.09	14.96	9.61	11.42	15.35	10	12.09	14.96	9.61
5"	13.23	16.93	11.02	14.29	16.14	11.02	13.23	16.93	11.02	14.29	16.14	11.02
6"	14.96	16.14	10.63	15.59	15.67	10.63	15.75	16.14	10.63	15.59	15.67	10.63
8"	18.74	22.05	13.39	19.96	19.29	12.6	19.69	22.05	13.39	19.96	19.29	12.6
10"	20	26.97	13.39	21.34	21.34	14.37	20	26.97	13.39	21.34	21.34	14.37
12"	26.22	29.92	16.54	26.38	29.92	16.54	26.22	29.92	16.54	26.38	29.92	16.54

unit:in